

P3: CAD

Larry Hui, Athul Krishnan, Eric Yamaguchi, Thomas Yu

CAD Diagrams

Top-Level Assembly

Motor/pulley subassemblies
for cable tensioning

Camera mounting
subassembly

Air hockey table

Mounting frame w/
leveling feet

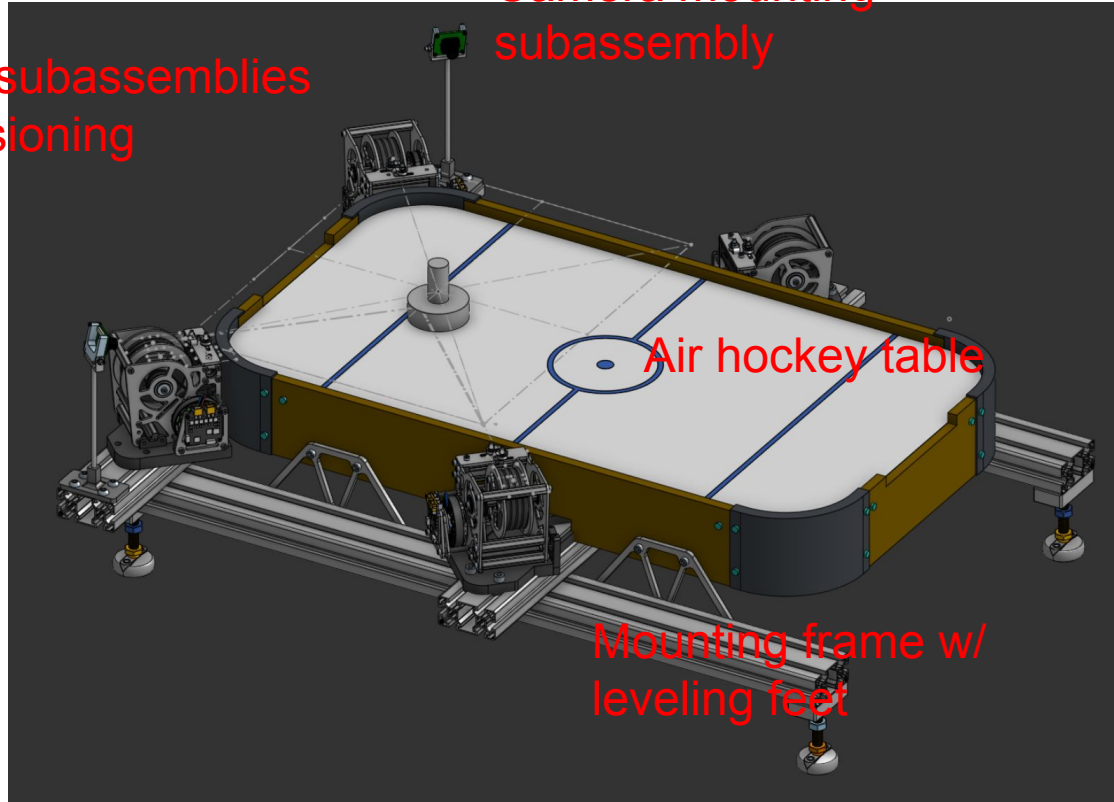

Motor Subassembly

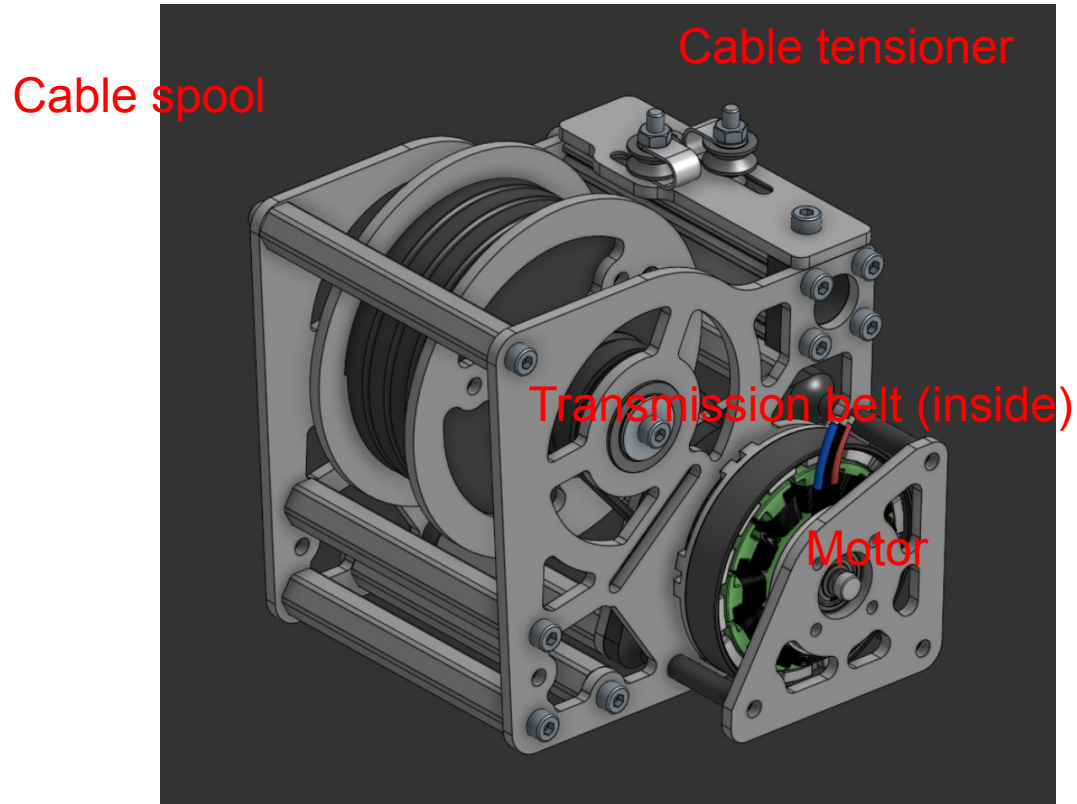

Frame Subassembly

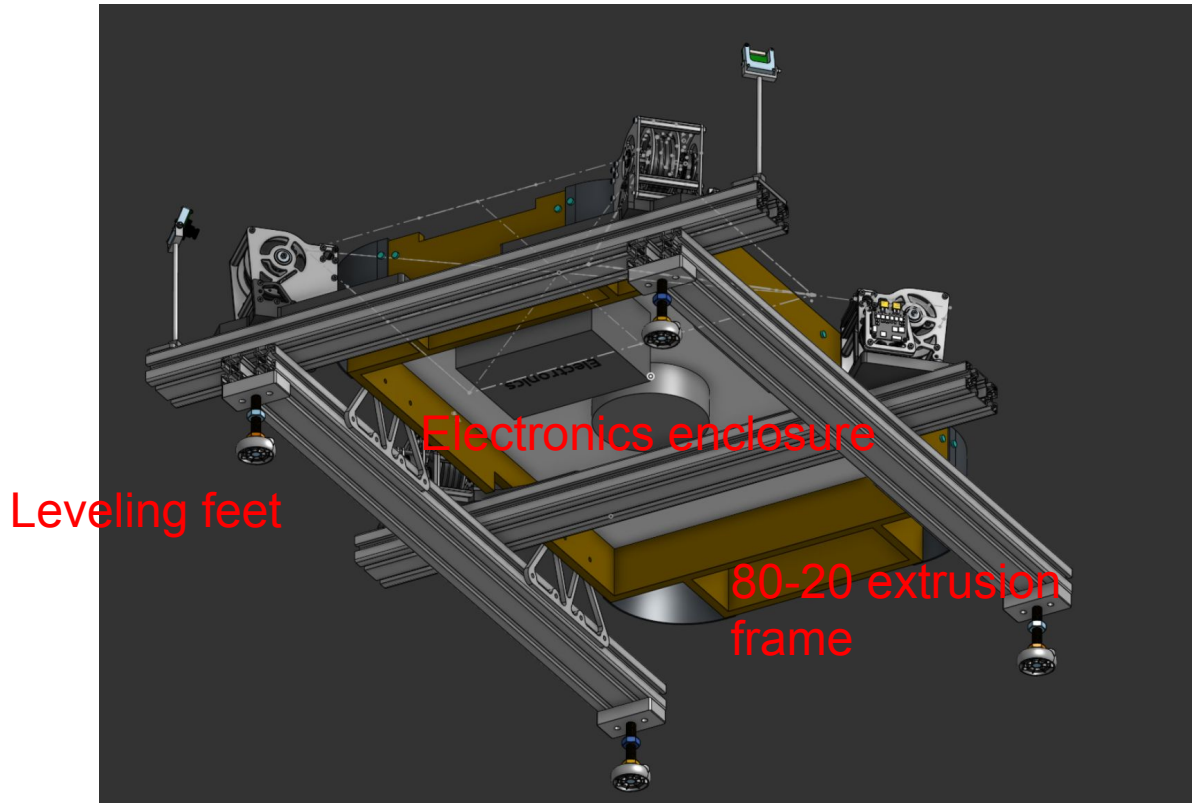

Camera Subassembly



Load Calculations

Transmission Calculations

Our assembly only has one transmission, linking the corner-based motor hub to the cable spool

- Mallet mass: 2 kg
- Max acceleration: 20 m/s^2
- Max tangential force = 40 N
- $R = 17 \text{ mm}$ (both sides)
- Max torque = 0.68 Nm

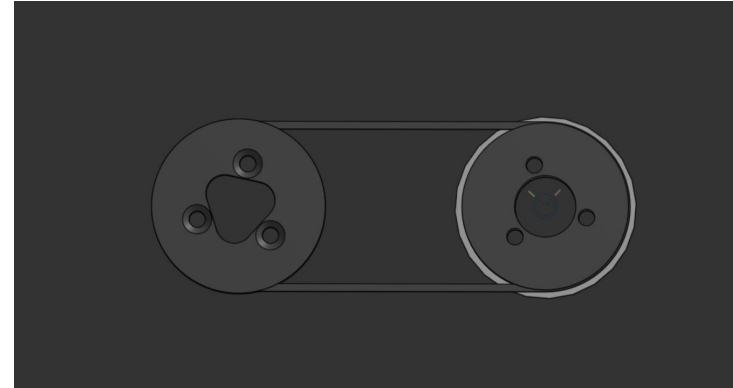

Bearing Calculations

The transmission force creates a bearing load on the axis of our spool:

- FBD is shown at right
- By inspection of the FBD, the bearing loads are less than the magnitude of the transmission force, so we have nothing to worry about

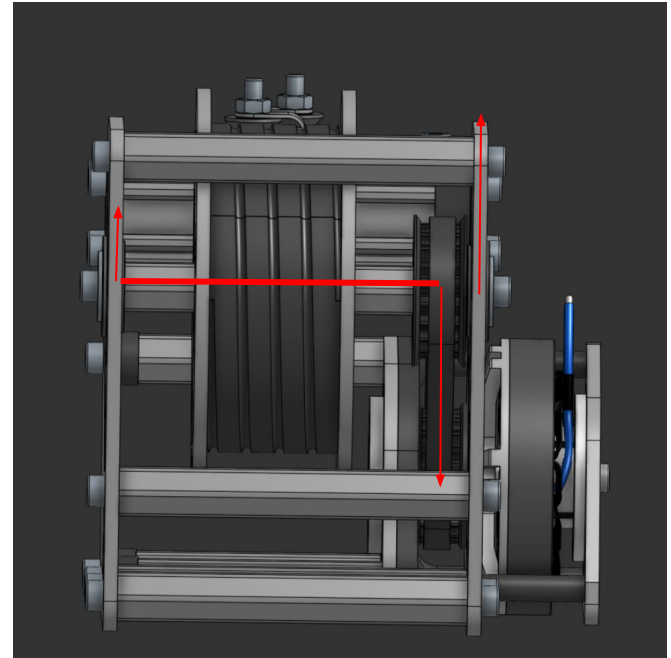

Spool Specifications

Spool calculations are done in this [spreadsheet](#).

We approximate the diameter, width, and windings necessary for a helical spool to meet our velocity and maximum cable length specifications, given 600W BLDC motors we have on hand. In the interest of time, we have not restated the formulas here.